

BIDDING ADDENDA
Section 00 91 13 / Rev: August 2021

Date: November 14 2024

Addendum Number: One (01)

Project Number: 9002418

Agency Name: Arkansas Department of Parks, Heritage, and Tourism

The proposed contract documents for this work are modified as follows:

1 INVITATION TO BID

1. Extend bid date from November 20, 2024 at 1:30 PM to December 12, 2024 at 1:30 PM.

2 SPECIFICATIONS

1. 00 11 16 - Invitation to Bid
 - a. Extend bid date from November 20, 2024 at 1:30 PM to December 12, 2024 at 1:30 PM.
2. 00 41 13 - Bid Form
 - a. Extend bid date from November 20, 2024 at 1:30 PM to December 12, 2024 at 1:30 PM.

3 DRAWINGS

1. Refer to sheet C4.00 - Site Details, Addendum 3, dated November 11, 2024:
 - a. For Typical Asphalt Pavement detail, Class 7 Aggregate Base Course to be compacted to 95% of Maximum Modified Proctor Density.
 - b. For Typical Asphalt Pavement detail, Class 7 Aggregate Base Course compacted to 95% of Maximum Modified Proctor Density.

Attachments:

00 11 16 Invitation to Bid

00 41 13 Bid Form

Sheet C4.00 - Site Details

INVITATION TO BID
Section 00 11 16 / Rev: August 2021

Ecological Design Group	Trotting Fox Trail Improvements
120 S. Iazard St. Little Rock, AR, 72201 501-378-0200	DBA Project #: 9002418 Owner/Agency: Arkansas Department of Parks, Heritage, and Tourism

- 1) You are invited to bid on a General Contract for the:
Construction of: Trotting Fox Trail Improvements
Located At: Mississippi River State Park, 2522 State Hwy 44, Marianna, AR 72360
Project Owner: Arkansas Department of Parks, Heritage, and Tourism
Bid Type: Lump Sum Basis: Lowest Responsive and Responsible Bidder

- 2) There will be a Pre-Bid Conference
Date: Wednesday, November 13, 2024
Time: 10:30 a.m.
Location: Mississippi River State Park Visitors Center, 2522 State Hwy 44, Marianna, AR 72360

The State reserves the right to schedule future meetings.

- 3) The Owner will receive bids until:
Date: Thursday, December 12, 2024
Time: 1:30 p.m.
Location: Division of Building Authority, 501 Woodlane St., Suite 101N, Little Rock, Arkansas 72201

Sealed bids may be mailed or delivered to the above address. Bids received after the date and time stated in the solicitation and will not be considered. Bids will be publicly opened and read aloud at the time and date mentioned. Interested parties are invited to attend. The Division of Building Authority, hereinafter termed DBA, unless designated to another entity, supervises the bidding and award of all construction contracts, approves contract change orders, request for final payment and ensures on-site observations are accomplished.

- 4) Obtaining contract documents through any source other than the Design Professional listed above or their representative(s) is not advisable due to the risks of receiving incomplete or inaccurate information. Contract documents obtained through the Design Professional or their representative(s) are considered the official version and take precedence should any discrepancies occur. The official version of the complete set of the contract documents should be examined and are obtainable from:

Ecological Design Group, 120 S. Iazard St., Little Rock, AR, 72201. Prospective Bidders may obtain or view the Bidding Documents, during business hours at: Southern Reprographics, 901 West 7th St., Little Rock, AR 72201, (501) 372-4011.

- 5) Bid document deposit and refund information:
A set of (3) printed copies of the Bidding Documents may be obtained by paying a deposit of \$100 per set to the issuing office. Deposit price does not include shipping, if required. Bidders who return full sets of the Bidding Documents in good condition within 10 days after opening of Bids will receive a full refund. A bidder receiving a contract award may retain the bidding documents and the Bidder's deposit will be refunded. Prime Bidders requiring additional sets and Sub-Bidders may purchase bidding documents through Southern Reprographics.

- 6) While contract documents can be examined at the following plan room(s), bidders should use caution in doing so:
Southern Reprographics, 901 West 7th St., Little Rock, AR 72201, (501) 372-4011

<https://SRIPlanRoom.com>

- 7) Bid Security in the amount of five (5) percent of the bid must accompany each bid in accordance with the Instructions to Bidders.

- 8) Bidders are hereby notified that any bidder who desires to enter into Contract for this work must comply with disclosure requirements pursuant to Governor Executive Order 98-04. Submission to the Owner and DBA of the completed Disclosure (DBA 00 73 73) form will be a condition of the Contract. The Owner cannot enter into any contract nor can DBA approve any contract, which does not obligate the Contractor to require the submission of Disclosure (DBA 00 73 73) forms for subcontracts exceeding \$25,000.
- 9) Bidders are hereby notified that prevailing wage rates will not apply
- 10) The State reserves the rights to reject any and all bids, and to waive any formalities. Bidders shall conform to the requirements of the Arkansas licensing laws and regulations for contractors, and shall be licensed before his bid is submitted unless the project is federally funded pursuant to Arkansas Code Annotated § 17-25-315.
- 11) Pursuant to Ark. Code Ann. § 22-9-203, the State encourages all small, minority, and women business enterprises to submit bids for capital improvements. Encouragement is also made to all general contractors that in the event they subcontract portions of their work, consideration is given to the identified groups.
- 12) Pursuant to Ark. Code Ann. § 19-11-105, the lowest responsible bidder shall certify prior to executing the contract that they do not employ or contract with any illegal immigrants. Bidders shall certify online at: <https://www.ark.org/dfa/immigrant/index.php/user/login>
- 13) Bidders are responsible to adhere to the guidelines established for state operated buildings. Face coverings should be worn upon entering the facility and whenever moving through common areas (lobbies, elevators, stairs, restrooms, meetings and hallway/corridors). Bidders without a face covering may be denied access at the point of entry. Due to social distancing requirements and health/safety concerns, prompt entrance to the building may not occur therefore, Bidders should be prepared for any delays into the building for a timely bid submittal.

BID FORM
Section 00 41 13 / Rev: August 2021

Bid Date: Thursday, December 12, 2024
Bid Time: 1:30 p.m.
Bid Opening Location: Division of Building Authority,
501 Woodlane St., Suite 101N,
Little Rock, Arkansas 72201

Bid To: Arkansas Department of Parks, Heritage, and Tourism

Bid From: _____

DBA Project Number: 9002418

Project Name: Trotting Fox Trail Improvements

- 1) Having carefully examined the Contract Documents for this project, as well as the premises and all conditions affecting the proposed construction, the undersigned proposes to provide all labor, materials, services, and equipment necessary for, or incidental to, the construction of the project in accordance with the Contract Documents within the time set forth, for the lump sum base bid of:

\$ _____
Dollar Amount Is To Be Shown Numerically

- 2) Allowances:
Not Required

- 3) Unit Prices:
Not Required

- 4) Trench or
Excavation
Safety: Not
Required

\$ _____
Dollar Amount Is To Be Shown Numerically

Please Note: Do not strike through or add language to the bid form. See Instruction to Bidders #6.1

5) Completion The Bidder agrees that the work will be complete in accordance with the contract
Date: documents and ready for Substantial Completion:

Number of Calendar Days: 90

On or Before Date:

6) The undersigned, in compliance with the Contract Documents for the construction of the above named project, does hereby declare:

a. That the undersigned understands that the State reserves the right to reject any and all bids and to waive any formality.

b. That if awarded the Contract, the undersigned will enter into an Agreement, on a form identical to the form included in the Contract Documents and execute required performance and payment bonds and proof of insurance within ten (10) days after receipt of the Intent to Award, will commence work within five (5) days after the start date of the Notice to Proceed, and will complete the Contract fully by Completion Date indicated. Should the undersigned fail to fully complete the work within the above stated time, he shall pay the Owner as fixed, agreed and liquidated damages and not as a penalty, the sum of:

Dollar amount of liquidated damages per day: \$250 until work is completed or accepted.

c. The undersigned further agrees that the bid security payable to Owner and accompanying this proposal shall become the property of the Owner as liquidated damages if the undersigned fails to execute the Contract or to deliver the required bonds and proof of insurance to the Owner within the time frame as stated in paragraph 6 (b) from receipt of the Intent to Award as these acts constitute a breach of the Contractor's duties.

d. That this bid may not be withdrawn for a period of: 30 calendar days after the bid opening.

e. The undersigned understands that the Owner's intent is to construct all facilities proposed within the limits established by the funds appropriated for the project.

f. The names of subcontractors and the nature of the work to be performed by each one have been included on the Bid Form.

g. The following prevailing wage rates will apply:
Bidders are hereby notified that prevailing wage rates will not apply.

Please Note: Do not strike through or add language to the bid form. See Instruction to Bidders #6.1

h. Bids submitted by a "Joint Venture/Joint Adventure" shall be signed by representatives of each component part of the Joint Venture/Joint Adventure. The licenses of each component part of the Joint Adventure should also be listed in the bid submittal. Therefore, Joint Adventure bidders shall indicate at least two (2) signatures and should indicate two (2) licenses numbers on the Bid Form. Exception: Joint Ventures who have been properly licensed with the Arkansas Contractors Licensing Board as a "Joint Venture" need only to indicate the Joint Venture license number on the Bid Form. Joint Venture Bidders shall indicate at least two (2) signatures on the bid form even if they are licensed as a Joint Venture.

7) The following document(s) is attached to and made a condition of this bid.

a. Bid Security

8) The undersigned acknowledges receipt of and inclusion as a part of the Contract Documents the following addenda(s):

#: _____	Dated: _____
#: _____	Dated: _____
#: _____	Dated: _____
#: _____	Dated: _____
#: _____	Dated: _____
#: _____	Dated: _____
#: _____	Dated: _____

Please Note: Do not strike through or add language to the bid form. See Instruction to Bidders #6.1

- 9) Listing of Mechanical, Plumbing, Electrical, and Roofing Subcontractors or the Prime Contractor if the portion of work will be performed with your own forces.

Important Please Note

Indicate the name(s) of each entity performing the listed work below and answer the follow-up question. All Mechanical, Plumbing, Electrical, and Roofing Subcontractors or your own forces if applicable shall be listed regardless of qualifications, licensures or work amount. Bidders should consult the project manual on how to fill out this form. Failure to name the subcontractor or prime contractor in the space provided shall cause the bid to be declared non-responsive and the bid will not receive consideration.

Mechanical:

Not Required

Plumbing:

Not Required

Electrical:

Not Required

Roofing:

Not Required

Important Notice: If the Bid Form notes any or all of the above Subcontractor's (Mechanical (HVACR), Electrical, Plumbing, and/or Roofing) as "**Required**", you must list a subcontractor or list your own forces as applicable or your bid will be declared non-responsive.

Bid Form Signature Page

Project Name: Trotting Fox Trail Improvements

Project #: 9002418

Please Complete the Appropriate Section (Complete Only One)

Individual Entity of Company

Legal Name of the Entity or Company Contractors License Number

By: _____
Signature of Authorized Officer of the Company Date

Print Name Email Phone Number

Street Address City State Zip Code

Corporation (Must Include with bid a copy of the authorized officer's authority to sign)

By: _____
Signed With Legal Name of the Corporation State of Incorporation Contractor License Number

By: _____
Signature of Authorized Officer of the Corporation Date

Print Name Email Phone Number

Street Address City State Zip Code

Joint Venture or Adventure

1st Entity or Company (*legal Name*) Contractors License Number

By: _____
Signature of Authorized Officer of the Company Date

Print Name Email Phone Number

Street Address City State Zip Code

2nd Entity or Company (*legal Name*) Contractors License Number

By: _____
Signature of Authorized Officer of the Company Date

Print Name Email Phone Number

Street Address

City

State

Zip Code



ADPHT TROTTING FOX TRAIL (TAP-22) (S)
ARDOT JOB 110768; DBA 9002418
Marianna, Arkansas

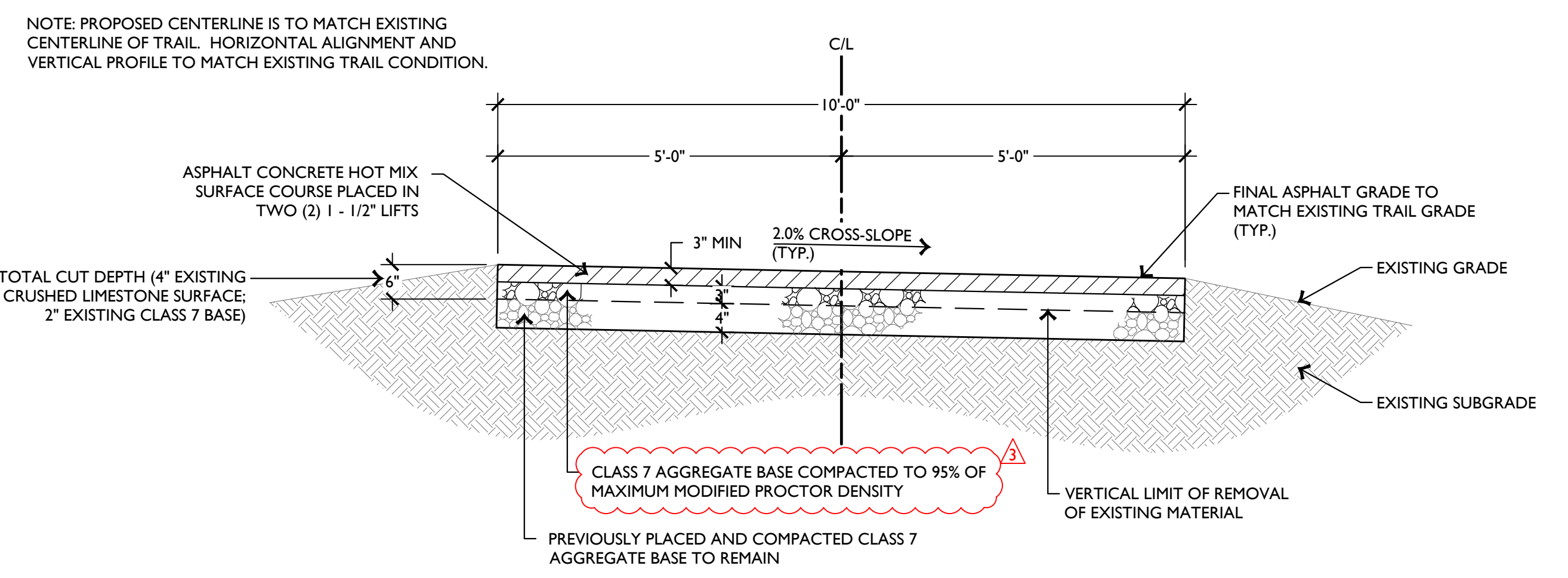

1 TYPICAL ASPHALT PAVEMENT

N.T.S.

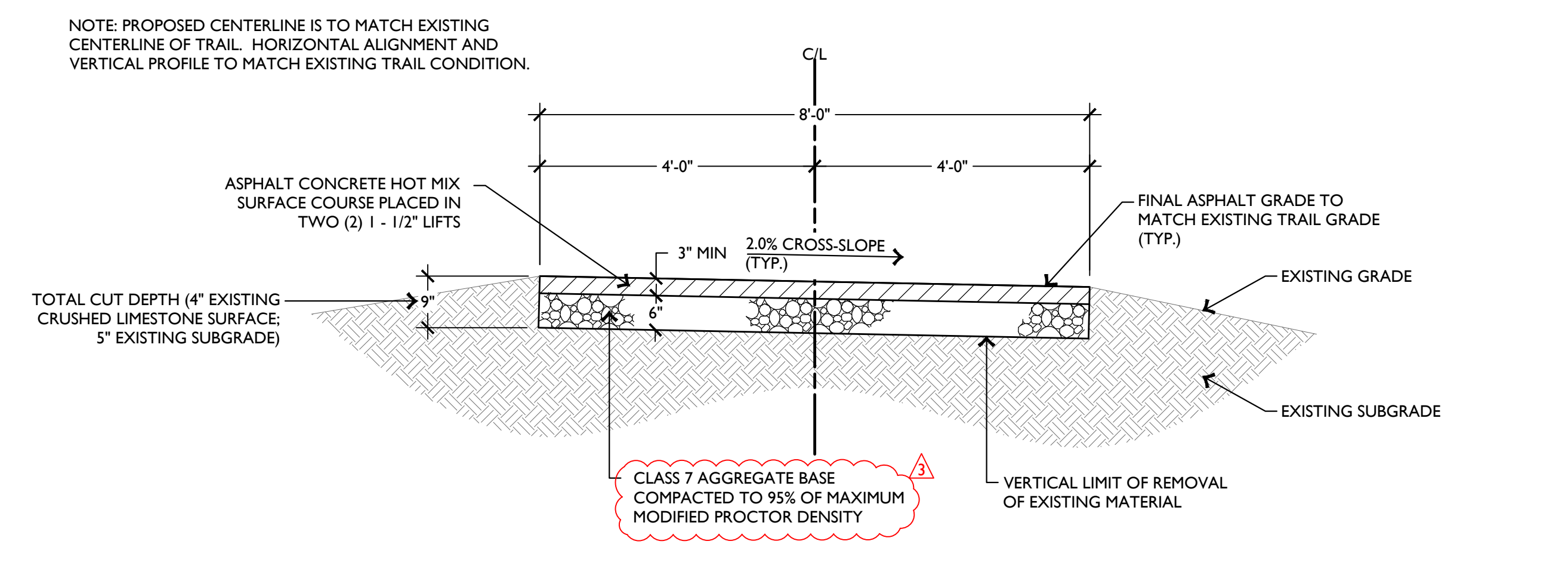

2 TYPICAL ASPHALT TRAIL AND PADS

N.T.S.

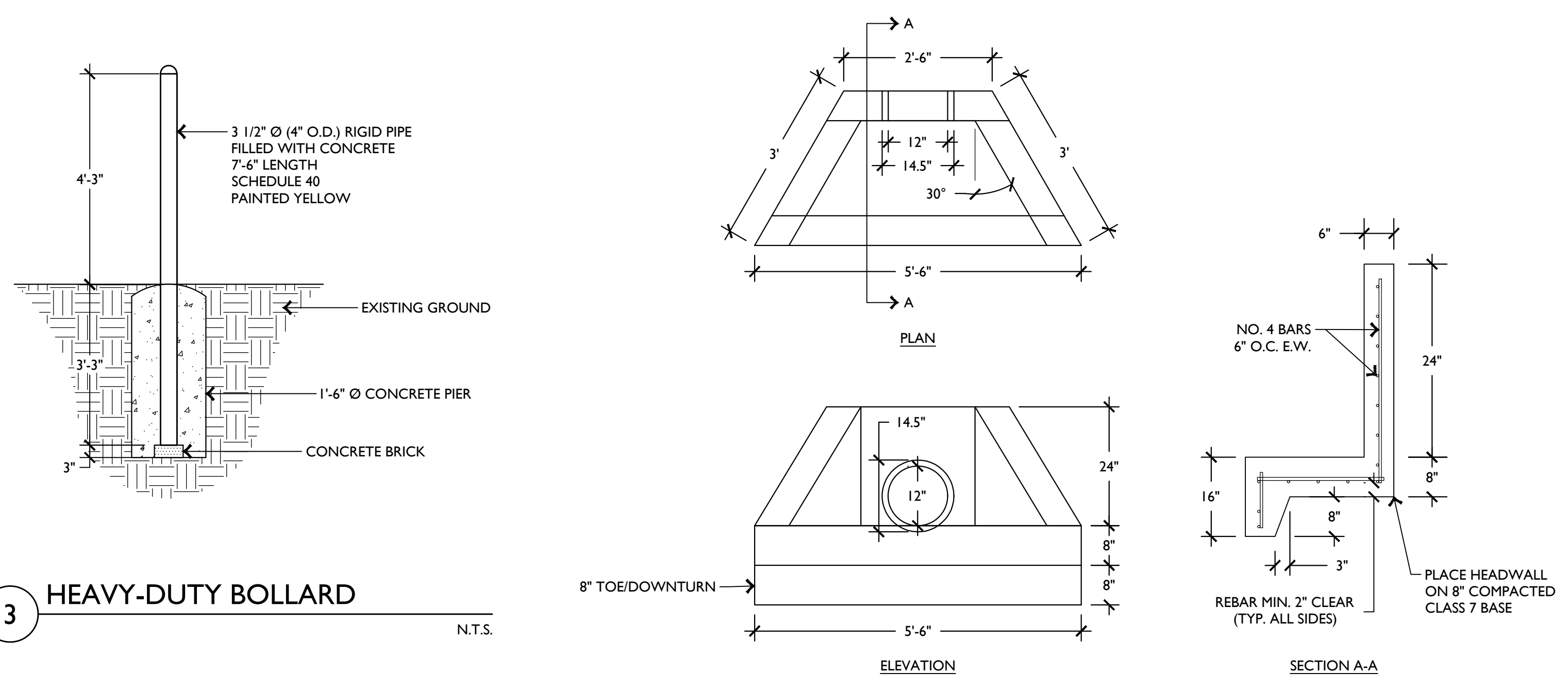

3 HEAVY-DUTY BOLLARD

N.T.S.

4 CAST-IN-PLACE CONCRETE HEADWALL 12" PIPE

N.T.S.

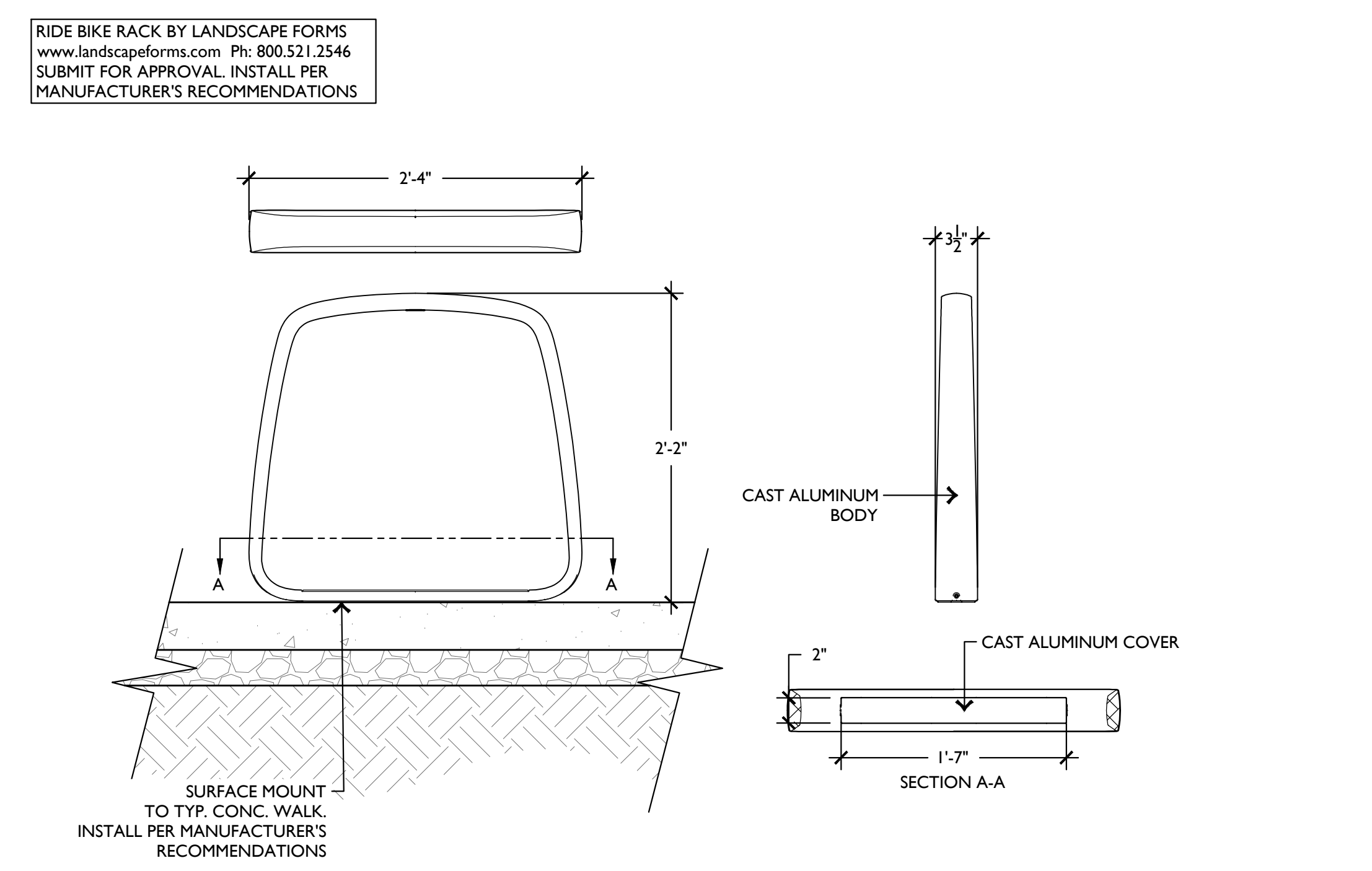

5 BIKE RACK

N.T.S.

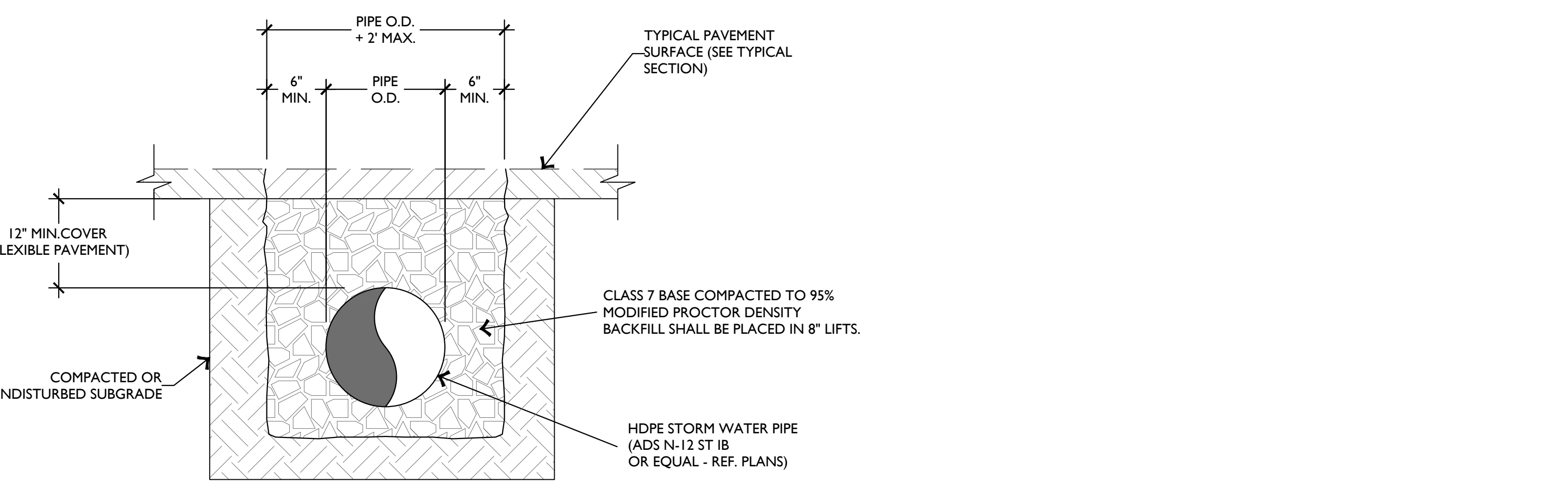

6 STORM PIPE BEDDING & BACKFILL

N.T.S.

NOTE:
TRENCHES OVER 5 FEET DEEP OR GREATER REQUIRE TRENCH OR EXCAVATION SAFETY SYSTEM PER OSHA EXCAVATION STANDARD 29 CFR SUBPART "P".

PAVED AREAS

EDG PROJECT NO. 23-047
DATE 2023.12.04

Mark	Date	Description
1	2024.02.07	Addendum 1
2	2024.08.29	Addendum 2
3	2024.11.13	Addendum 3

PHASE 100% Construction Drawings

TITLE Site Details

SHEET NO. **C4.00**